

Hydraulic Pump (General)

	Piston pump (for high and medium pressure applications)	Gear pump (for medium and low pressure applications)	Vane pump, screw pump, etc. (for low pressure applications)
Products included in this catalog.	Axial piston pump in swashplate design For closed circuit For open circuit (for excavator, mini-excavator, etc.)	External gear pump (for forklift truck, agricultural machine, and general purpose products)	
KYB products not included in this catalog. (Contact KYB)	Load sensing pump for mixer truck Axial piston pump in bent axis design		Vane pump (for automobile power steering and industrial equipment)
Not included in KYB product lineup		Internal gear pump	Screw pump

Pump: Gear pump

[General Description]

High reliability is the primary policy for developing KYB pumps and is based on long experience in various applications, advanced technology and excellent production technology. The KFP series pumps having cast-iron bodies are those of high performance, light in weight, compact in design, and durable.

Basic Construction

[Construction and Mechanism]

1. The shaft connected to the gear is driven by an engine or an electric motor.
 2. While the gears are rotating, the oil filling the gear tooth grooves is moved from the suction port to the delivery port.
- ※ The shaft is designed to be rotated in one direction to realize high performance. When placing an order, please specify the direction of shaft rotation: C rotation (clockwise viewing from the shaft end) or A rotation (anti-clockwise viewing from the shaft end).
- Note: Rotating the pump in the direction opposite to the design will damage the inside of the pump and render it unusable.

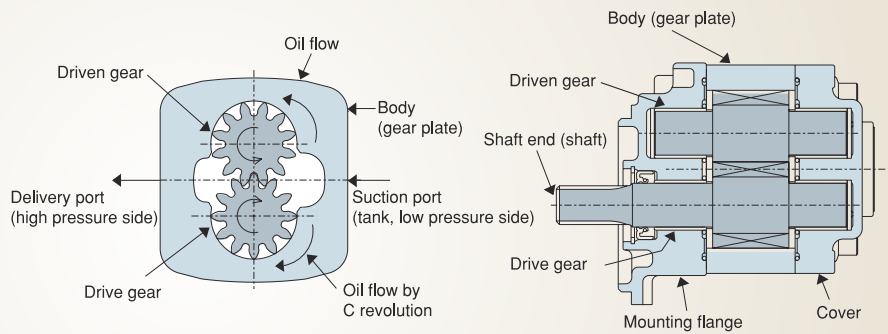

Basic characteristics

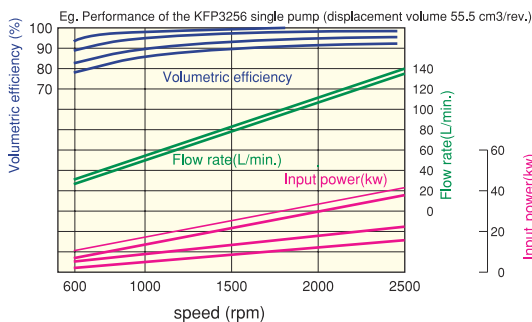

- Volumetric efficiency (actual flow / theoretical flow)
Operation at a low speed and high pressure increases internal leakage causing low performance.
- Input power (theoretical shaft power / mechanical efficiency)
Operation at a high speed and high pressure increases shaft power.
- The actual flow and actual input power are related to the speed and pressure. Please contact KYB if the properties of each model need to be clarified.

Displacement of each Model

	Displacement (cm ³ /rev)						
	0	20	40	60	80	100	120
KP05	—						
KFP23		—	—				
KFS23		—	—				
KFP32			—	—	—		
KFS32			—	—			
KFP51					—	—	—

※ Please consult KYB when selecting an appropriate gear pump model under the same displacement.

■ KP, KFP, and KFS Series (Single)

[Model code] <Single series>

Example KFP23 23 A P *
1 2 3 4 5~7



KP05

KFP23.KFS23

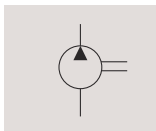

Symbol

1	Gear pump series	KP, KFP, and KFS (low pulsation type)
2	Pump displacement	Nominal displacement (cm ³ /rev)
3	Direction of rotation	A (anticlockwise viewing from the shaft side) or C (clockwise)
4	Shaft end	S (spline) or P (straight). Other signs indicate special configurations.
5~7	Additional information	Port position (side or rear), port configuration, mounting flange shape, shaft end seal, etc.

	Displacement (cm ³ /rev)	Max. operating pressure (MPa)	Speed min-max. (rpm)	Max. flow rate (L/min.)	Weight (kg)	Old model (approx. displacement value)	
						Old model name	Compatibility
KP05	3.0-13.2 (10 types)	20.6	600-3000	39	1.6-1.7	GPI	○
KFP23	11.9-33.3 (10 types)	20.6	600-3000	100	2.4-4.3	KRP4 KFP22	△ ○
* KFS23	12.5-32.8 (10 types)	20.6	600-3000	100	2.4-4.3	DGP4 KFS4	△ △
KFP32	20.0-60.0 (11 types)	20.6	600-3000	125	3.9-11.4	2P3000	△
* KFS32	20.7-51.6 (9 types)	20.6	600-3000	125	3.9-9.5	—	—
KFP51	63.0-125.0 (7 types)	20.6	600-2500	250	20.5-24.7	KP50	○

* KFS is a low pulsation type

○: Compatible

△: Compatible except for the port

※ Low pulsation gear pump (KFS series)

KFS23 series and KFS32 series are low pressure pulsation version of KFP23 series and KFP32 series. Noise in hydraulic systems is generally caused by the pressure pulsation created by the pump and dual flank engagement gear technology is utilized for these gear pump series to reduce the pressure pulsation.

■ KFP Series (Tandem)

[Model codes] <Tandem series> (Dual and triple models)

Example KFP23 19 - 19 - 12 A (Triple model)
1 2 3 4 5

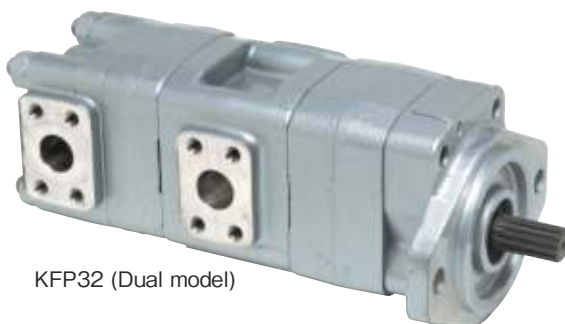

KFP32 (Dual model)

1	Gear pump series	KFP
2	Front pump displacement	Nominal displacement (cm ³ /rev)
3	Center pump displacement	Nominal displacement (cm ³ /rev). No sign for the tandem dual model
4	Rear pump displacement	Nominal value (cm ³ /rev)
5	Direction of rotation	A(anticlockwise)or C(clockwise)

Each series is available with a variety of tandem models

	KFP23	KFP32	KFP51
Dual	○	○	○
Triple	○		
Tandem combination with different models		○	○

※ The front pump represents the model name of the tandem combination with different models.

※ The displacement of the front pump needs to be greater than that of the rear pump or the same.

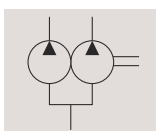

Symbol

[Caution to specify a tandem pump(Dual or Triple)]

- Two or three pumps are driven with a single shaft.
- Specifications of each pump are the same as the single pump.
- Supply hydraulic fluid from the single reservoir, even if the front, center (in the triple model), and rear pumps have separate suction ports.
- Set the displacement volume as follows: Front pump \geq Center pump \geq Rear pump
- When only the front pump is operated, the maximum operating pressure may be applied. When multiple pumps are loaded simultaneously, however, the torque value (T value) in the following Q x P formula should not be exceeded.

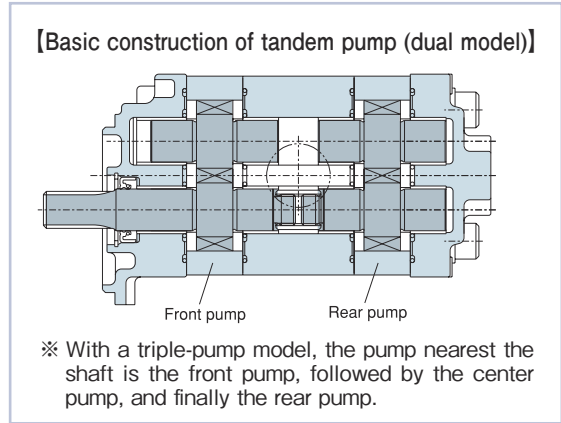

<Q x P expression (T value)> ※ T values (TT, TR, and TC): Simple expression to obtain allowable shaft torsional torque

For dual model: $(QF \times PF) + (QR \times PR) \leq TT$
 $(QR \times PR) \leq TR$

QF: Front pump displacement (cm³/rev)

PF: Front pump pressure (MPa)

QC: Center pump displacement (cm³/rev)

PC: Center pump pressure (MPa)

QR: Rear pump displacement (cm³/rev)

PR: Rear pump pressure (MPa)

For triple model: $(QF \times PF) + (QC \times PC) + (OR \times PR) \leq TT$
 $(QC \times PC) + (QR \times PR) \leq TC$
 $(QR \times PR) \leq TR$

TT, TC, and TR values

Model	Shaft Specification	T T	T C	T R
KFP23	DP16/32: 10T spline	543.3	Front pump is less than 19 cc/rev.: 288.5 Front pump is over 23 cc/rev.: 633.5	288.5
	DP16/32: 11T spline	633.5		
KFP32	DP16/32: 13T spline	1479	1030	-
	DP16/32: 14T spline	1886		
KFP51	DP16/32: 14T spline	3957	2368	-

Coupling hole unit: mm

● Spline: L

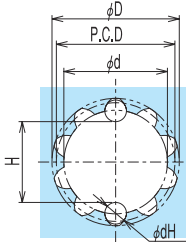

Model	D. P	T o o l pressure angle	No. of Teeth	P.C.D	d	d H	Direct drive without flexible coupling		Drive with flexible coupling	
							H	D	H	D
KP05	Module 1.0	20°	12	12	12.000 ~ 12.020	2.000	10.067 ~ 10.137	13.970 ~ 14.500	-	-
KFP23 KFS23	16/32	30°	10	15.875	14.465 ~ 14.592	2.743	11.834 ~ 11.912	17.463 ~ 17.742	11.463 ~ 11.561	17.048 ~ 17.078
			11	17.463	16.020 ~ 16.147		13.287 ~ 13.358	19.050 ~ 19.329	12.958 ~ 13.041	18.636 ~ 18.666
KFP32 KFS32	16/32	30°	13	20.638	19.134 ~ 19.261	2.743	16.521 ~ 16.588	22.225 ~ 22.504	16.229 ~ 16.300	21.811 ~ 21.842
			14	22.225	20.700 ~ 20.827		18.267 ~ 18.329	23.812 ~ 24.092	17.961 ~ 18.037	23.400 ~ 23.430
KFP51	12/24		14	29.634	27.589 ~ 27.716	3.657	24.342 ~ 24.407	31.750 ~ 32.080	24.188 ~ 24.255	31.505 ~ 31.539

● Straight: M

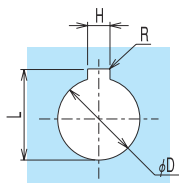

Model	D	L	H	R
KP05	12.5 ^{+0.018} / ₀	14 ^{+0.2} / _{+0.1}	4 ^{+0.015} / ₀	0.3
KFP23 KFS23	21.02 ^{+0.030} / _{+0.005}	23.27 ^{+0.1} / ₀	5 ^{+0.03} / ₀	0.25 ~ 0.4
KFP32 KFS32	22 ^{+0.028} / _{+0.007}	24.8 ^{+0.15} / ₀	6 ^{+0.030} / ₀	
KFP51	30 ^{+0.028} / _{+0.007}	30.3 ^{+0.2} / ₀	8 ^{+0.036} / ₀	

Dimensions (unit: mm)

KPO5

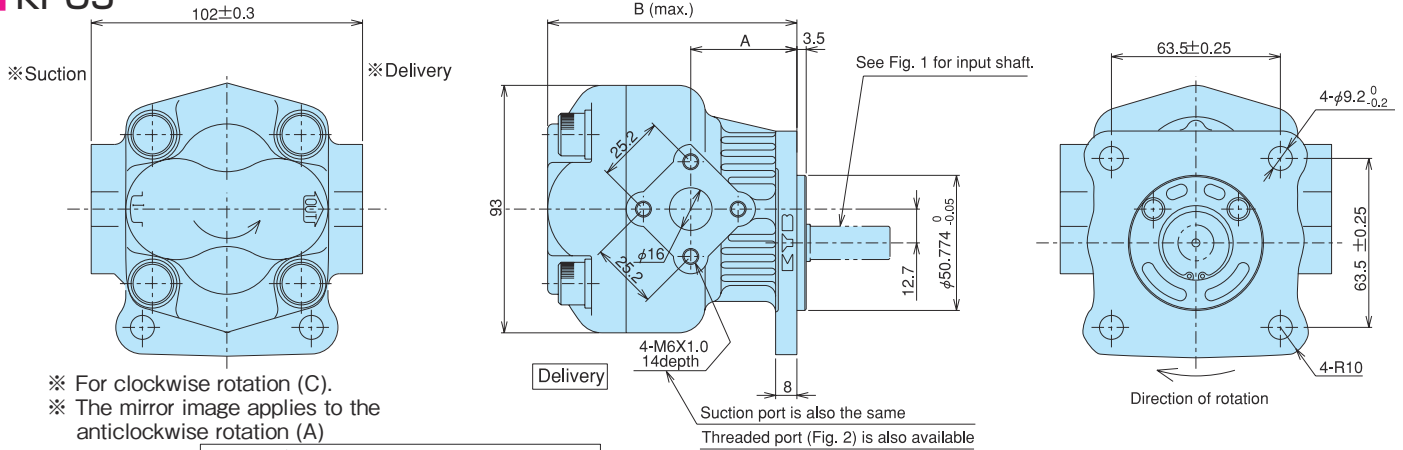

- ※ For clockwise rotation (C).
- ※ The mirror image applies to the anticlockwise rotation (A)

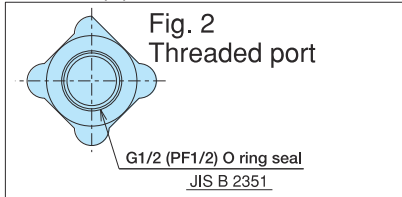
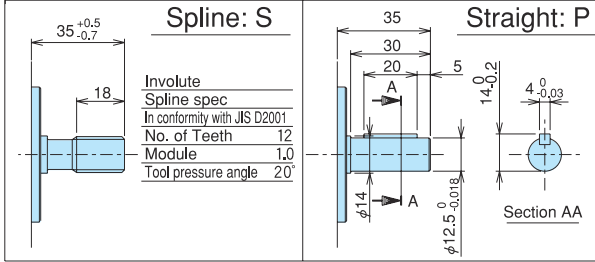

Fig. 1 shaft end



KPO5 displacement, specifications, and dimensions (details)

Model	Displacement (cm ³ /rev)	Max. operating pressure (MPa)	Speed (rpm)	A (size)	B (size)	Weight (kg)
KP0530	3.0	20.6	600 ~3000	39.9	93.5	1.6
KP0535	3.5					
KP0540	4.0					
KP0553	5.3					
KP0560	6.0					
KP0570	7.0					
KP0588	8.8	17.2	43.7	97.3	1.7	
KP05106	10.6					
KP05123	12.3					
KP05132	13.2					

KFP23/KFS23

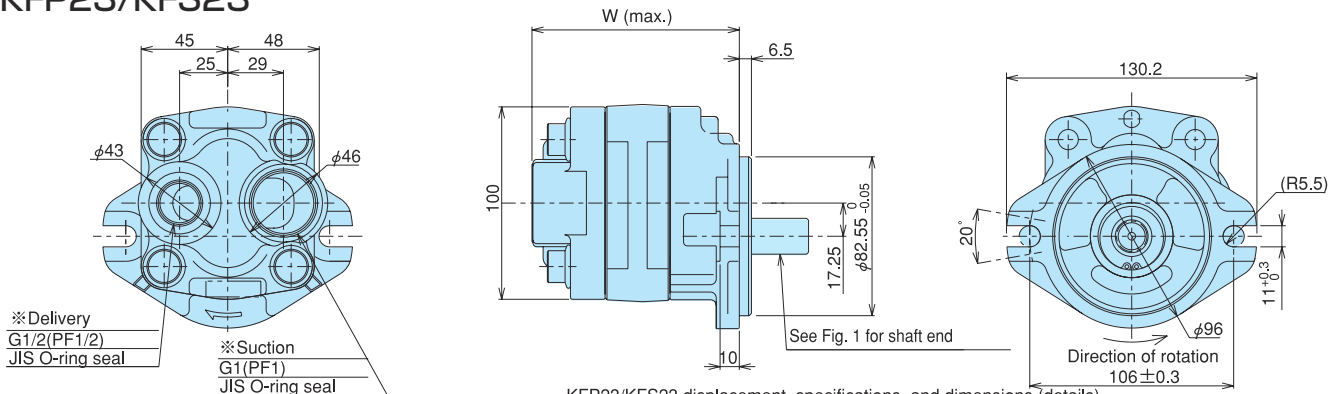

- ※ For anticlockwise rotation (A)
- ※ The mirror image applies to the clockwise rotation (C).

The side port type is also available.

KFP23/KFS23 displacement, specifications, and dimensions (details)

Standard pump (KFP)		Low pulsation pump (KFS)		Specifications		Dimensions and Weight	
Model	Displacement (cm ³ /rev)	Model	Displacement (cm ³ /rev)	Max. operating pressure (MPa)	Speed (rpm)	W mm	Weight (kg)
KFP2312	11.9	KFS2312	12.5	20.6	600 ~3000	96.5	2.4
KFP2314	14.3	KFS2315	15.0			99.6	2.6
KFP2317	16.8	KFS2317	17.6			102.9	2.8
KFP2319	19.2	KFS2320	20.2			106.1	3.0
KFP2323	22.9	KFS2324	24.0			110.9	3.5
KFP2325	24.5	KFS2325	25.7			113.1	3.7
KFP2327	26.5	KFS2327	27.8			115.7	3.8
KFP2328	28.2	KFS2329	29.4			117.7	3.9
KFP2330	30.0	KFS2331	31.2			120.0	4.1
—	—	KFS2333	32.8			122.0	4.3
KFP2333	33.3	—	—			124.3	4.3

Fig. 1 Shaft end

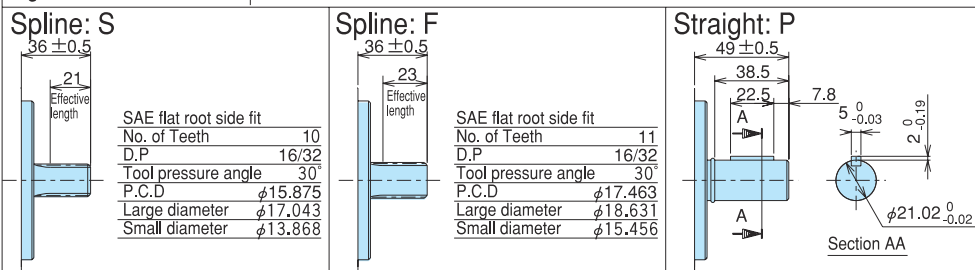

KFP23 Tandem

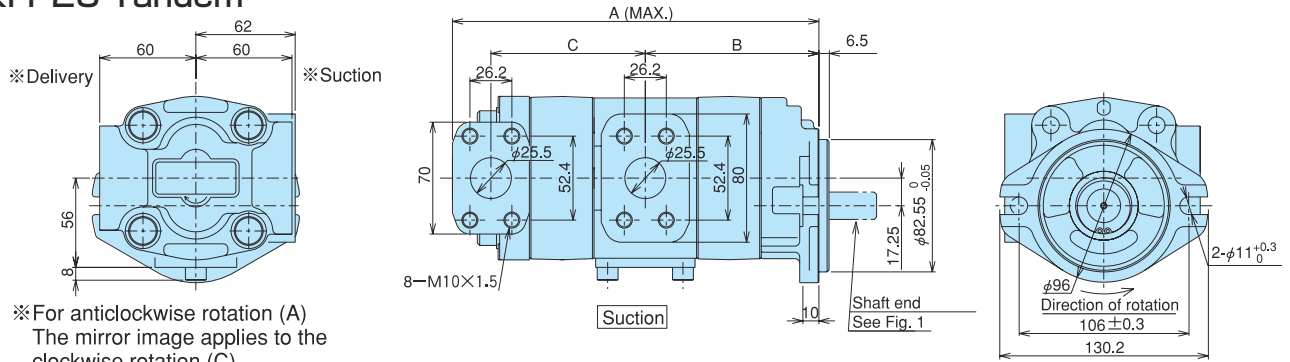

※ For anticlockwise rotation (A)
The mirror image applies to the clockwise rotation (C).

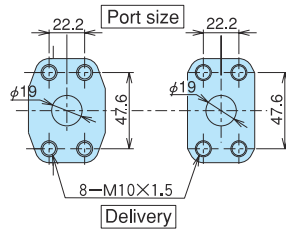

Fig. 1 Shaft end

Spline: S	Spline: F
SAE flat root side fit	SAE flat root side fit
No. of Teeth 10	No. of Teeth 11
D.P 16/32	D.P 16/32
Tool pressure angle 30°	Tool pressure angle 30°
P.C.D φ 15.875	P.C.D φ 17.463
Large diameter φ 17.043	Large diameter φ 18.631
Small diameter φ 13.868	Small diameter φ 15.456

- ◇ KFP23 tandem (dual and triple) are available.
- ◇ When the max flow rate is less than 100 l/min, the common suction port on the front unit can be used.

- ※ Formula to calculate A, B and C (See Table 1.)
YF = Front pump Y length, YR = Rear pump Y length.
- (1) If KFP2319 or a smaller pump is used as a front pump
 - A = 141.1 + YF + YR
 - B = 63.8 + YF
 - C = 52.0 + YR
 - (2) If KFP2323 or a larger pump is used as a front pump
 - A = 149.1 + YF + YR
 - B = 67.8 + YF
 - C = 56.0 + YR

Table 1. KFP23 tandem displacement, specifications, and dimensions (details)

Model	Displacement (cm ³ /rev)	Max. operating pressure (MPa)	Intermittent max. pressure	Speed (rpm)	Y
KFP2312	11.9	20.6	24.5	600~3000	21.8
KFP2314	14.3				25.0
KFP2317	16.8				28.3
KFP2319	19.2				31.4
KFP2323	22.9				36.3
KFP2325	24.5				38.4
KFP2327	26.5				41.1
KFP2328	28.2				43.1
KFP2330	30.0				45.4
KFP2333	33.3				49.7

KFP32 Tandem

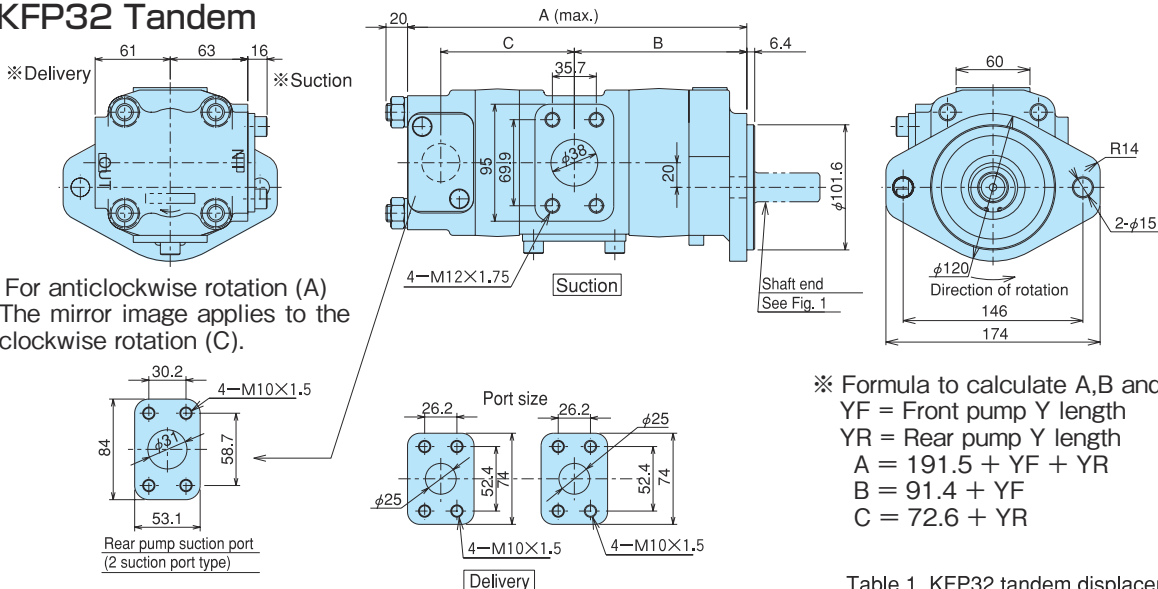

※ For anticlockwise rotation (A)
The mirror image applies to the clockwise rotation (C).

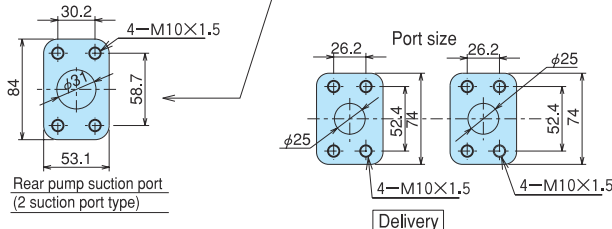

- ※ Formula to calculate A, B and C (See Table 1.)
YF = Front pump Y length
YR = Rear pump Y length
- A = 191.5 + YF + YR
 - B = 91.4 + YF
 - C = 72.6 + YR

Table 1. KFP32 tandem displacement, specifications, and dimensions (details)

Model	Displacement (cm ³ /rev)	Max. operating pressure (MPa)	Speed (rpm)	Y length	
KFP3220	20.0	20.6	600~3000	33.4	
KFP3223	22.5			35.9	
KFP3225	25.0			38.3	
KFP3228	28.0			41.3	
KFP3232	31.5			44.8	
KFP3236	35.5			48.7	
KFP3240	40.0			53.2	
KFP3245	45.0			600~2600	58.1
KFP3250	50.0			600~2500	63.0

- ◇ KFP32 tandem (dual) pump is available.
- ◇ When the max. flow rate is less than 190 l/min., the common suction port on the front unit can be used.

Performance Curve (Hydraulic fluid: ISO VG32, oil temperature: 50°C)

※ The typical displacements of models of each series are illustrated. Please consult us for models of other displacements.

KP0540

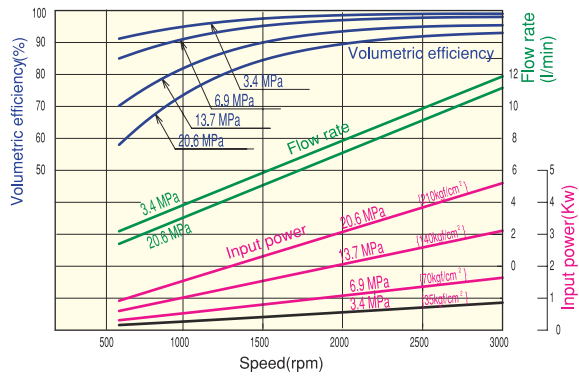

KP05123

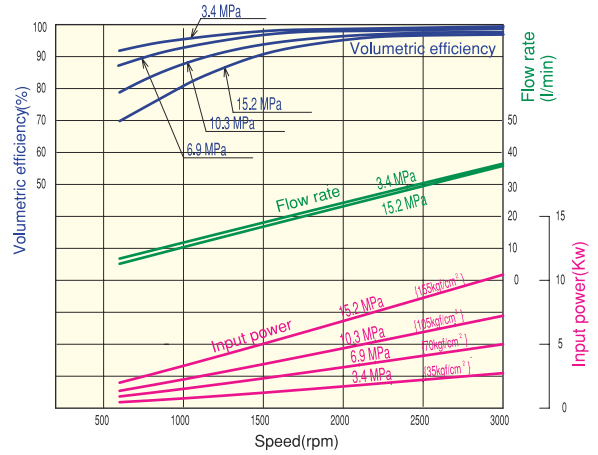

KFP2319

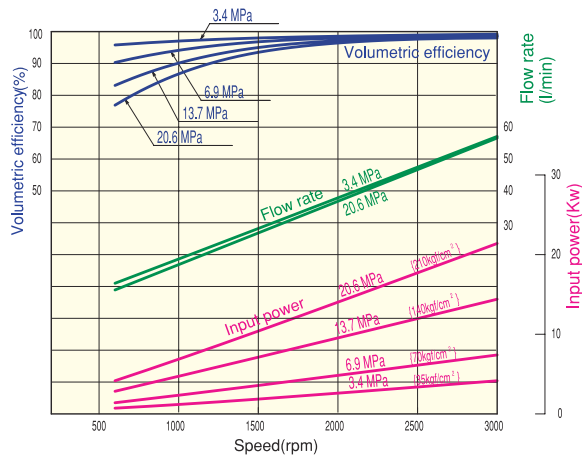

KFP2333

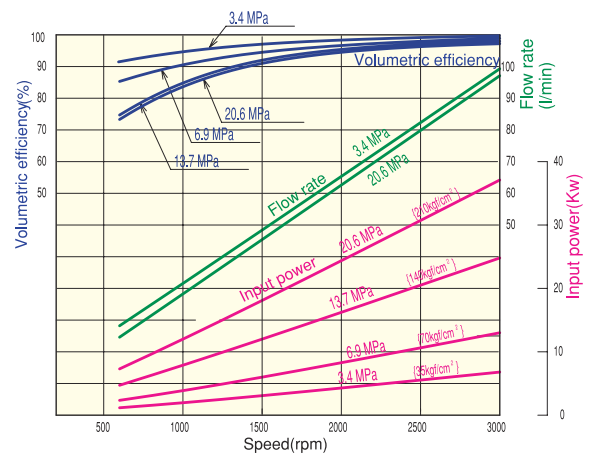

KFS2320

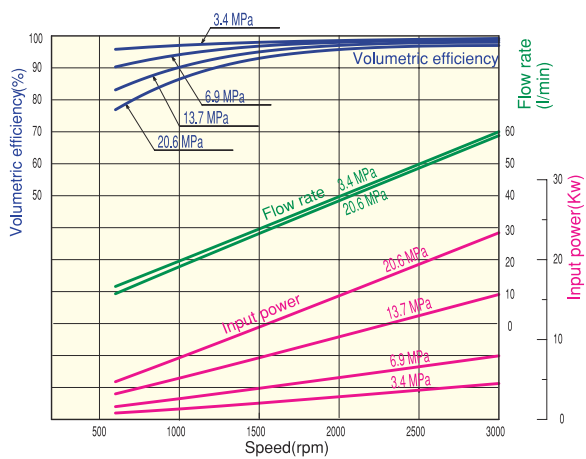

KFS2333

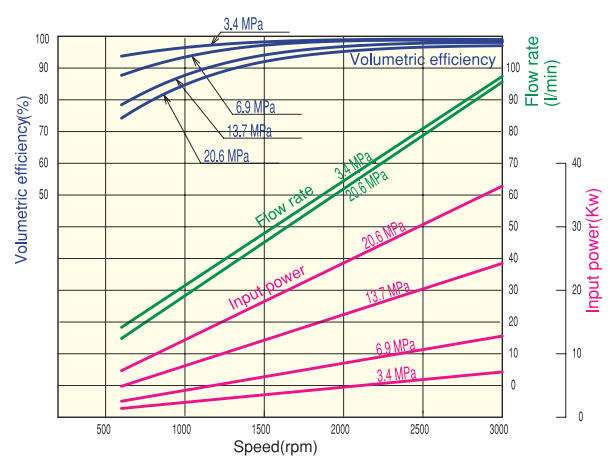

KFP3228

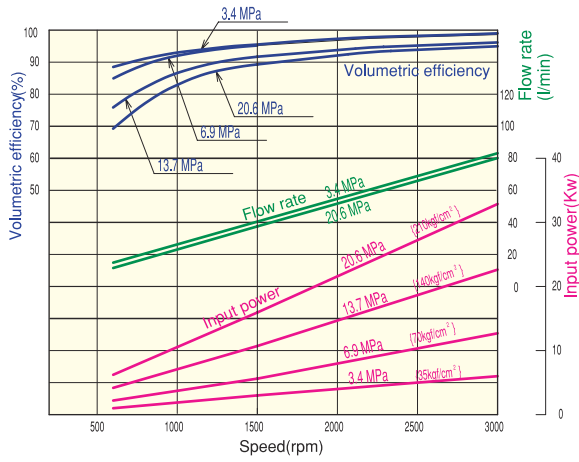

KFP3256

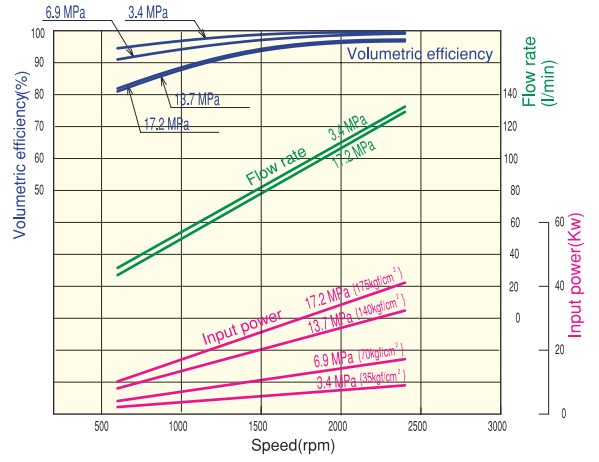

KFS3236

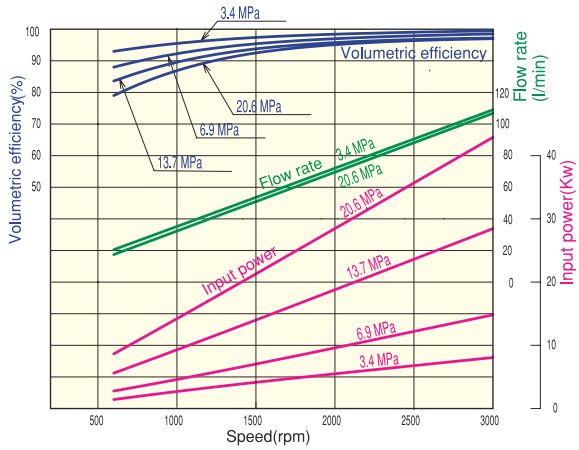

KFS3252

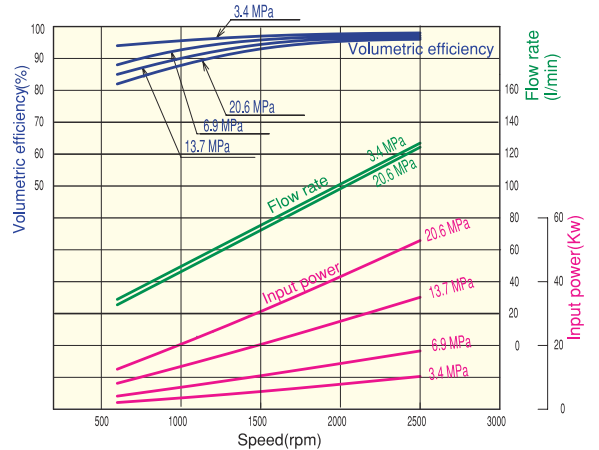

KFP5163

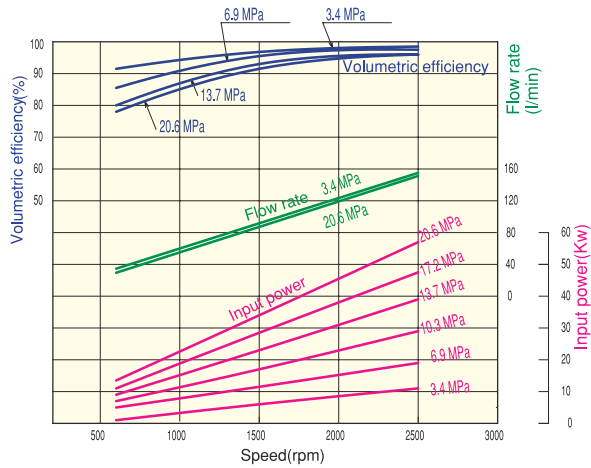

KFP51100

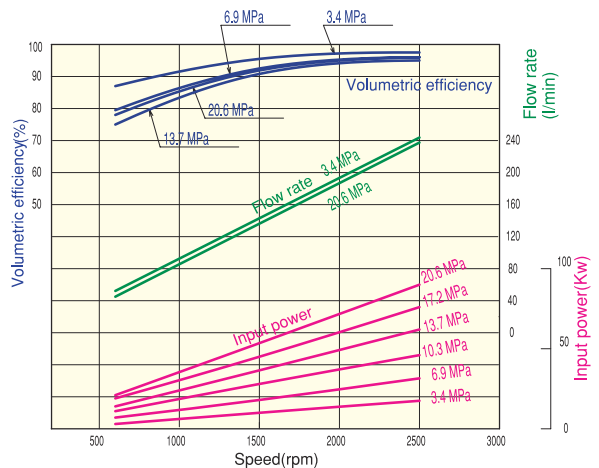

Pump: Swashplate type piston pump

[General Description]

KYB's piston pumps are used for construction equipment, agricultural machines, and other industrial equipment in a wide variety of market sectors. All series are high-performance, high-reliability piston pumps developed on an abundance of experience in numerous applications. They are manufactured by advanced production systems. This catalog provides only piston pumps for general-purpose closed circuit applications and construction equipment open circuit applications. All rotary parts are manufactured by one of KYB's affiliated companies, Takako Industries, Inc., which is the world's leading company in this technology.

Basic Construction

※ This piston pump has the same basic structure with the piston motor, and is equipped with additional pump functions. The direction of rotation of the input shaft is fixed.

[Construction and Mechanism]

1. The input shaft connected to the driving power source rotates. So does the connection between the cylinder block and the input shaft is made by the spline.
2. Then, the pistons reciprocate along the cylinder bores in a movement determined by the swash plate's tilting angle.
3. When the pistons are pulled out from the cylinder block, oil is drawn from the reservoir. When the pistons are pushed in, oil is delivered to the valve and actuator side.
4. The suction port and delivery port are divided by the valve plate.

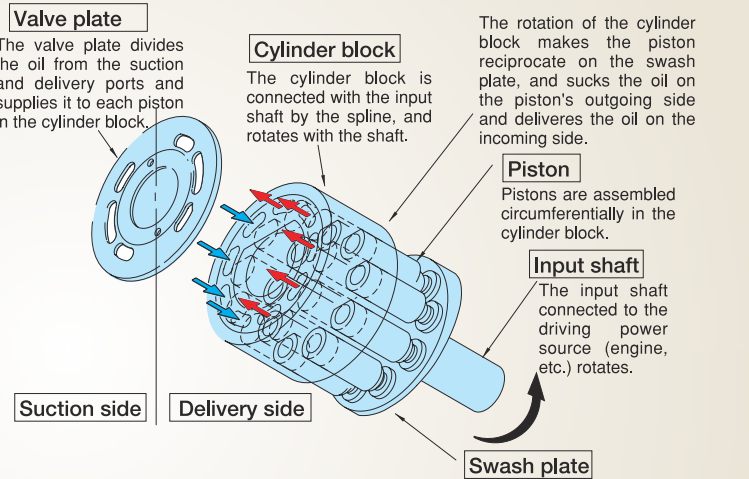

<Variable displacement pump>

1. The greater the tilting angle of the swash plate, the greater the reciprocation stroke (displacement) of the piston. When the angle is 0, the reciprocation of the piston stops, reducing the discharge volume to zero.
2. In the closed circuit, the delivery side and suction side are reversed as the swashplate tilting angle shifts from +a to -a even though the rotating direction of the input shaft remains unchanged.

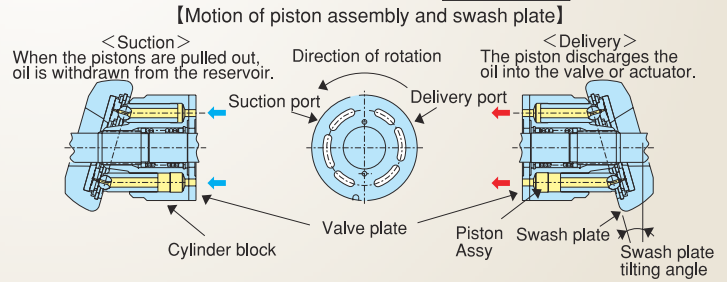

Basic characteristics

When selecting the pump, examine the following characteristics.

■ Volumetric efficiency, input horsepower, and mechanical efficiency

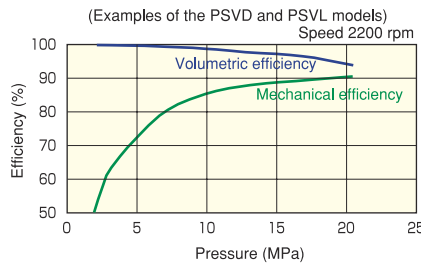
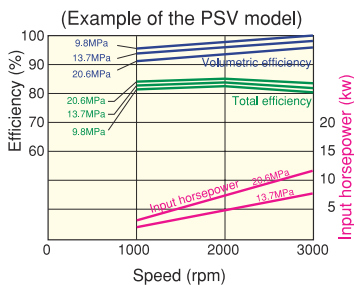

- Volumetric efficiency (actual flow rate / theoretical flow rate)
An operation at a low speed and high pressure increases internal leakage decreasing volumetric efficiency.
- Actual horsepower (theoretical horsepower / mechanical efficiency)
An operation at a higher speed and higher pressure increases mechanical efficiency.
- The actual delivery flow rate (volumetric efficiency) and actual shaft power are related to the speed and pressure. Please contact us regarding the specific characteristics of individual displacement volumes of each model.

■ Pressure and flow characteristics (horsepower control characteristics)

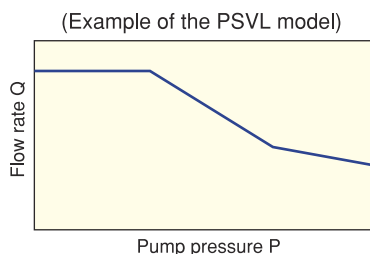
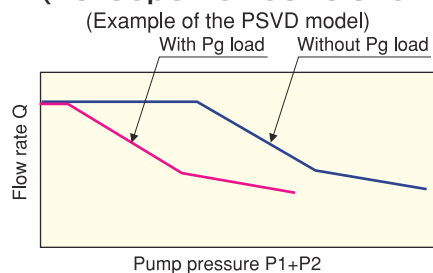

P1: First pump pressure P2: Second pump pressure Pg: Gear pump pressure

■ LS Control characteristics

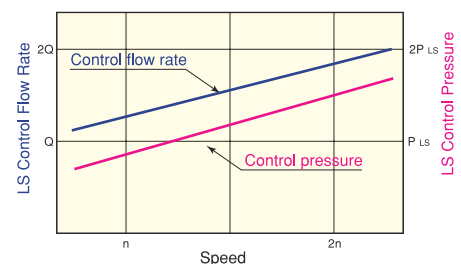

※ It is possible to control the flow rate almost proportional to the pump rotating speed.

Closed Circuit and Open Circuit

● Closed circuit

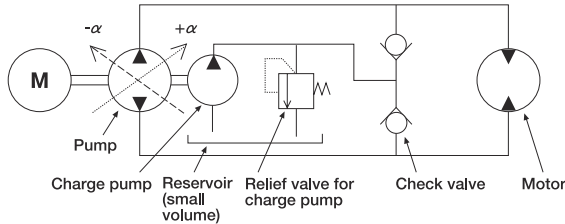

1. The closed hydraulic circuit is constructed with an actuator (motor) and a pump.
2. The speed and direction of the actuator can be decided by changing the pump tilt angle to $+ \alpha$, or to $- \alpha$ as the delivery port and the pump flow change accordingly.
3. The closed circuit features a smooth starting and stopping of the actuator.
4. The pump and the motor can be put into one case and made into a compact size as integrated HST.

● Open circuit

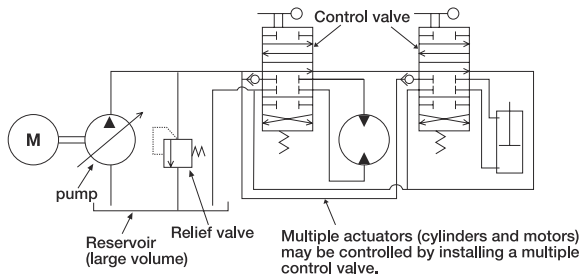

1. In the open circuit, oil is drawn by the pump from the reservoir, and the returning oil from the actuator is flown to the reservoir.
2. With a fixed-displacement pump, the speed and direction of an actuator are controlled with the switching and spool opening of the control valve. With the variable displacement pump, the pump controls the flow rate and the swash-plate tilting angle can be changed only in the $+ \alpha$ direction.
3. In the open circuit, a single pump can connect to and control multiple actuators.

Main Functions

[Variable Displacement]

The pump displacement can be changed by external control of the swash-plate tilting angle. (A two-way delivery flow in the closed circuit.)

- Manual type: The swash plate angle is controlled with a lever link.

<Regulator>

The regulator for the control of the swash plate angle of an open circuit pump has the following control devices:

- Horsepower control: The swash plate angle (and the pump displacement) changes depending on the pump delivery pressure in order not to exceed the engine horsepower, thereby making constant the maximum input torque to the pump, and ultimately making constant the pump's horsepower consumption. This control is effective in preventing the engine from stalling due to the pump power consumption exceeding the engine power, and in utilizing the engine horsepower efficiently. (PSVD)
- Load sensing control: This control aims to deliver the required flow that matches the ongoing operation. The pump delivers the required flow to the actuator at required pressure. The pump swash plate angle (and pump displacement) fluctuates so that differential pressure between the upstream and downstream sides of the LS valve can remain constant. Then, no sufficient flow and less heat generation can be made, which generates energy-saving system.

[Tandem pumps (Dual, Triple)]

- Two or three pumps are driven with a single input shaft. Flow rates in the first and second pumps can be set independently. The piston pump is used to drive travel motors. The third pump may be used as a charge pump in the closed circuit as well. (PSV2)

In the tandem configuration, the second pump is connected with coupling in the axial direction.

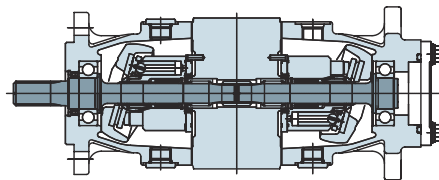

<Tandem dual configuration (single flow)>

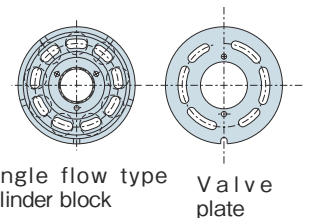

Single flow type cylinder block

Valve plate

[Single flow and split flow]

- As described in the basic construction of the piston pump, a typical piston pump is a single flow type with one suction port and one delivery port. On the other hand, a split flow type pump has two independent delivery systems with alternately positioned ports on a single cylinder block. (PSVD)

<Split flow>

※ A single cylinder block with a two flow system

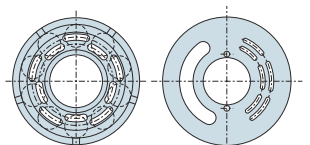
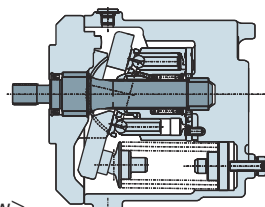

Split flow type cylinder block with each port split into internal and external ports for separate delivery

Valve plate

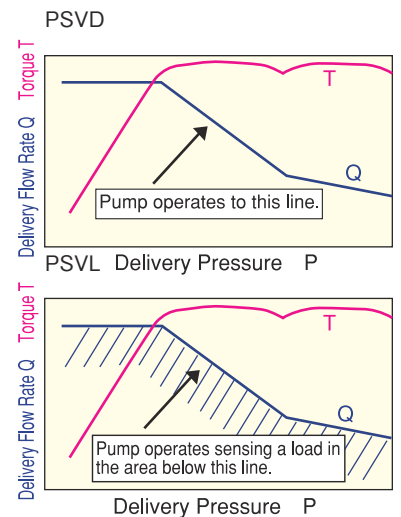

Pump: Piston Pump

Typical piston pumps are variable and high-pressure types mainly used for construction equipment, etc, engaged in heavy-duty work. They are widely used in areas that require horsepower control, load-sensing, and other control functions.

[Model codes] **PSV** **D2** - **13** **E**
 Example 1 2 3 4

1	Variable-displacement swash plate type piston pump
2	Pump type Void: Single pump, 2: Tandem pump (dual type), D2: Split-flow pump (Single cylinder block with two flow systems), L: Load-sensing pump S: Load sensing pump for truck mixer
3	Pump displacement Nominal (cm ³ /rev)
4	Additional information E: Series symbol

PSV Series (Closed circuit)



PSV2-16

Model	Displacement (cm ³ /rev)	Max. working pressure(MPa)	Max. speed (rpm)	Typical input horsepower(kw)
PSV-10	10.0	27.5	3,600	8.0
PSV-16	16.4	27.5	3,600	13.2
PSV2-10	10.0×2	27.5	3,200	7.0×2
PSV2-16	16.4×2	27.5	3,200	11.7×2

※ The direction of rotation of the input shaft is to be set in one direction. Please specify either "CW" or "CCW" as the direction of rotation.

PSVD Series (Open circuit)



PSVD2-21

Model	Displacement (cm ³ /rev)	Max. working pressure(MPa)	Max. speed(rpm)	Control device control (N·m)
PSVD2-13E	13.1×2	24.5	2,550	Horsepower control
PSVD2-17E	16.8×2	24.5	2,550	
PSVD2-21E	20.8×2	24.5	2,400	
PSVD2-27E	26.9×2	24.5	2,400	

※ Only CW is available (clockwise when viewing from the input shaft side).

PSVL Series (Open circuit and load sensing)

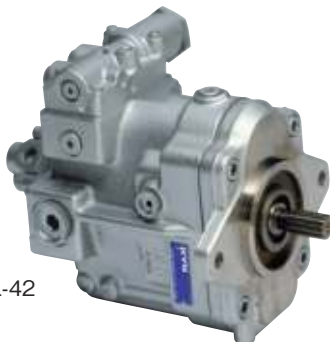

PSVL-42

Model	Displacement (cm ³ /rev)	Max. working pressure(MPa)	Max. speed (rpm)	Control device control (N·m)
PSVL-42	42	24.5	2,500	Horsepower control
PSVL-54	54	24.5	2,400	Load-sensing control

※ Load sensing type variable displacement pump
 ※ Use together with a load-sensing (LS) valve. (See Page 49.)
 ※ Only CW type is available (clockwise when viewing from the input shaft side).

<Open Circuit>

■ PSVD2-13, 17, 21 and 27 [Split flow (Single cylinder block with two flow systems)]

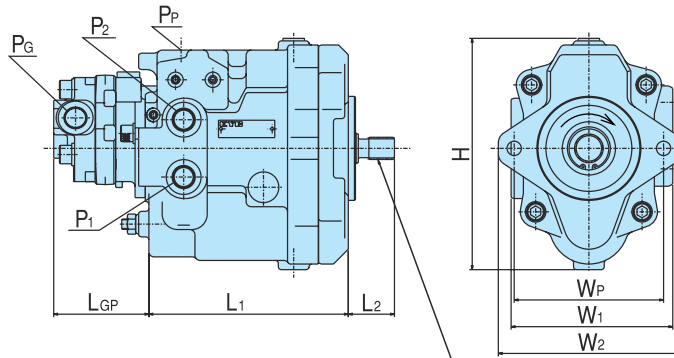
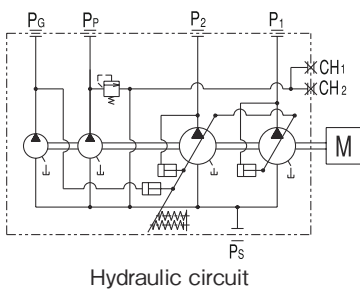

Involute spline
SAE J498b 16/32-13T

	Dimensions						Mounted dimensions		Port sizes			
	L1	L2	LGP	W1	W2	H	WP	D	P1	P2	PG	Pp
PSVD2-13E	166	46	90 ~	160	181	208	146	14	G3/8(PF3/8)	G3/8(PF3/8)	G1/2(PF1/2)	G1/4(PF1/4)
PSVD2-17E	181	46		160	181	221			G1/2(PF1/2)	G1/2(PF1/2)	G1/2(PF1/2)	G1/4(PF1/4)
PSVD2-21E	199	57	106	160	181	226			G1/2(PF1/2)	G1/2(PF1/2)	G1/2(PF1/2)	G1/4(PF1/4)
PSVD2-27E	217	52		181	234	252			G1/2(PF1/2)	G1/2(PF1/2)	G1/2(PF1/2)	G1/4(PF1/4)

■ PSVL-42 and 54 [Load sensing] ※ To be used with an LS valve. (See Page 55.)

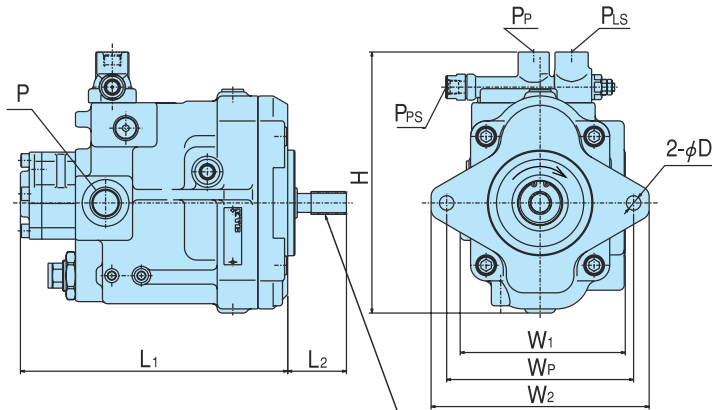
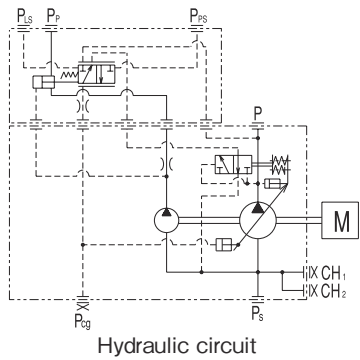

Involute spline
SAE J498b 16/32-15T

	Dimensions				Mounted dimensions			Port sizes			
	L1	L2	W1	W2	H	WP	D	P	Pp	Pps	PLs
PSVL-42	260	57	159	214	252	180	14	G3/4(PF3/4)	G3/8(PF3/8)	G1/4(PF1/4)	G1/4(PF1/4)
PSVL-54	284	48	180	234	258	200	17.5	G3/4(PF4/8)	G3/8(PF3/8)	G1/4(PF1/4)	G1/4(PF1/4)

Performance Curve Operating oil: ISOVG46 Oil temperature: 50°C

<Closed circuit>

■ PSV-10

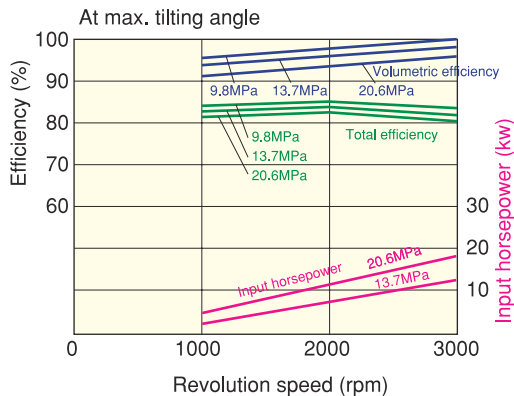

■ PSV-16

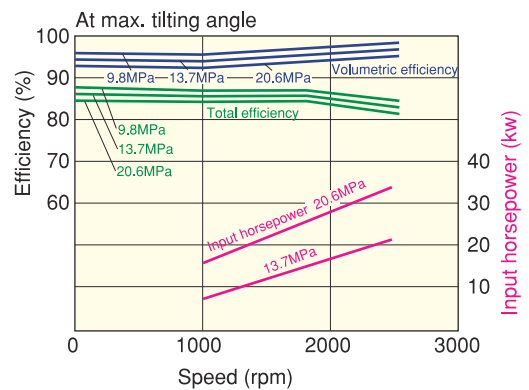

<Open Circuit>

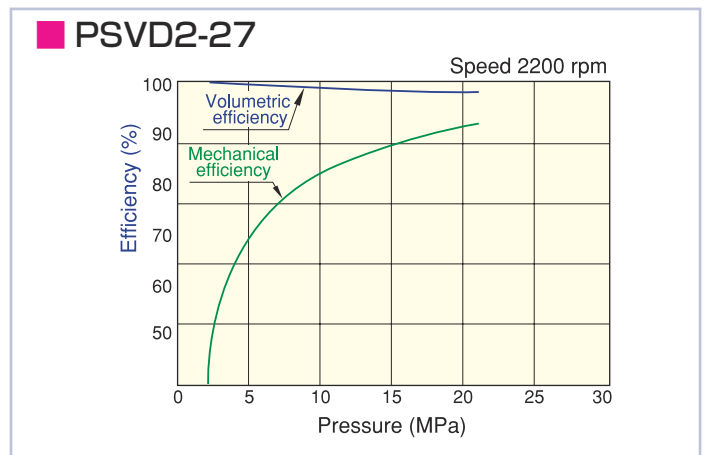
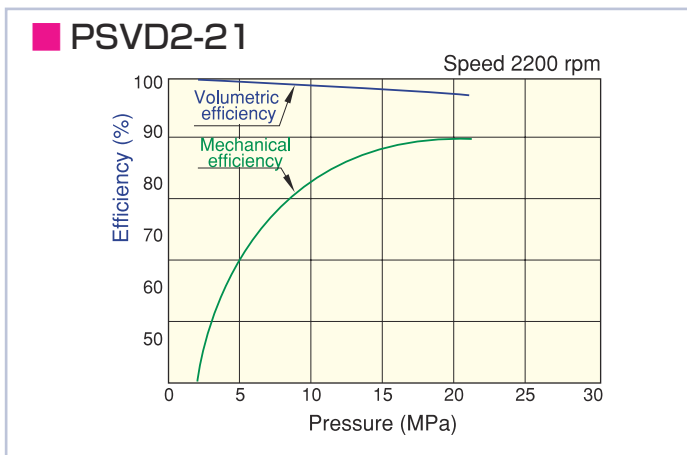
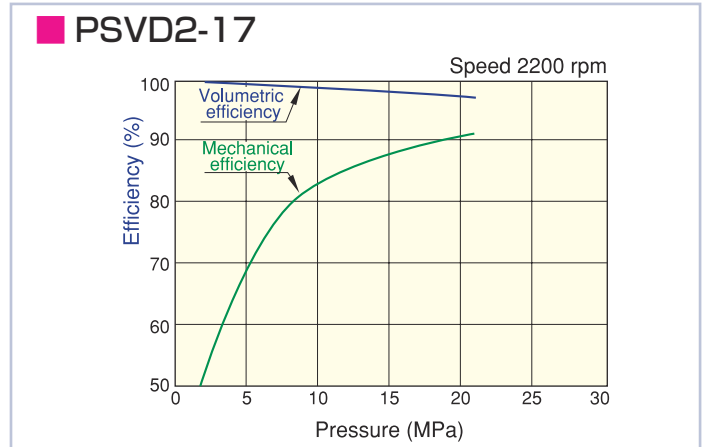
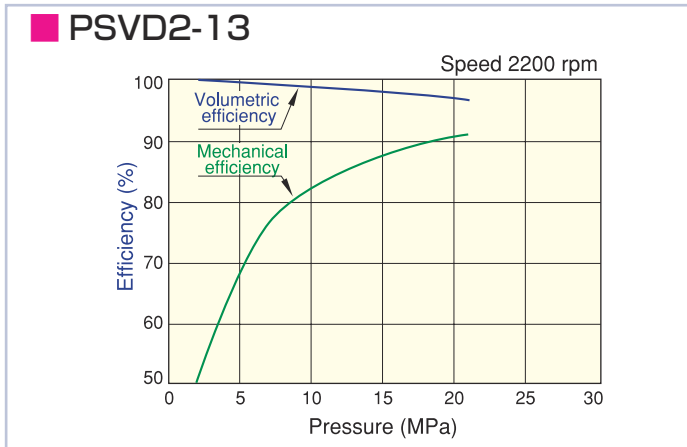

<Open Circuit: Load sensing>

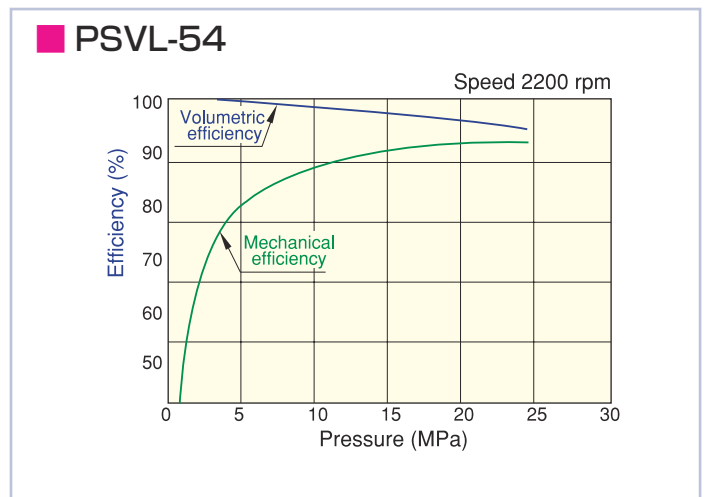
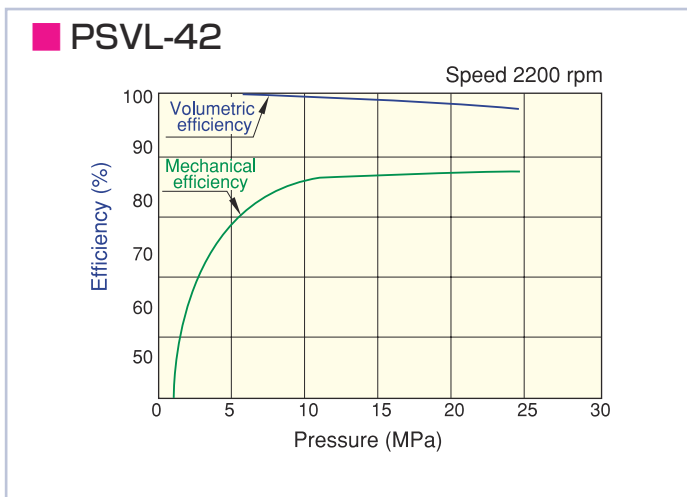

<Load sensing system working mechanism>
(multiple operations)

- The maximum load pressure P_L is selected by the shuttle valve, which controls the pump regulator and the pressure compensator valve.
- The pressure compensator valve adjusts the flow at A_c so that PC upper stream pressure equals $(P_L + \beta)$
- Differential pressure $(P_p - P_c)$ between the upperstream and downstream sides of A_1 and A_2 , which control the flow to each actuator, remains constant, enabling multiple operations under different loading conditions.

